



I Application

The RF pump is a flexible impeller pump. Due to the design, these pumps are reversible and self-priming and can suction from a maximum height of 5 meters. This type of pumps is designed to pump products of both low and high viscosity as well as materials containing particles or gases.

The main applications are transfer of dairy products, edible oils, wine, concentrates and beverages in general. They can also be used with viscous food products such as jam and marmalade, custard as well as cosmetic products such as soap, gel, toothpaste and creams. This pump is also used in the dyeing, textile and chemical industries.

I Operating principle

Due to the eccentric shape of the pump housing, a vacuum is created in the suction side that enlarges the volume between the blades and this causes the product suction.

The rotor is spinning and the product is carried from the suction side to that of delivery. Due to the eccentric shape of the pump housing, in the discharge side the blades bend, reducing the volume between them and causing the discharge of the product.

I Design and features

Bare shaft or close-coupled construction.

Reversible and self-priming pump.

Machined investment casting casing.

Double flat drive of the impeller.

Connections DIN 11851.

External single mechanical seal.

IEC motor: B34, 1500 rpm, 3 ph, 230/400 V, 50 Hz, IP55.

Easy maintenance.

White painted.

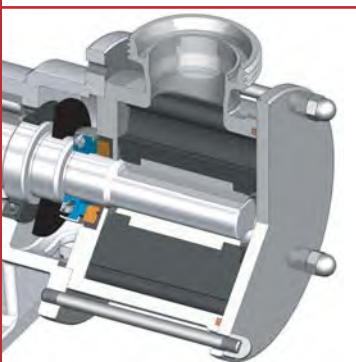

I Materials

Parts in contact with pumped media	AISI 316L
Lantern and bearing support	GG 22
Other parts	AISI 304
Impeller	CR (Neoprene)
Gaskets	NBR
Mechanical seal	Cer/C/NBR
Surface finish	polished, Ra ≤ 0.8 μm

I Options

Impeller: food grade neoprene.

SiC/C and SiC/SiC mechanical seals.

Lip seals.

Connections: SMS, Clamp, Macon, etc.

Motors with other protections.

1000 and 750 rpm motors.

2 speed motors.

Motors with frequency converter.

Electric panel with 10 m cable.

Stainless steel trolleys.



I Technical specifications

Max. flow	28 m ³ /h	132 US GPM
Max. working pressure*	2 - 4 bar	29 - 58 PSI
Max. working temperature	80 °C	176 °F
Max. speed	1500 rpm	

* according to the model



TYPE	DN	Flow ⁽¹⁾ [m ³ /h]	Max. differential pressure [bar]		Speed [rpm]
			close-coupled	bare shaft	
RF-02/20 S	25	1,4	3	4	1500
RF-05/25 S		4			
RF-10/40 S	40	9	2,5		
RF-20/50 S	50	20	2	2	
RF-30/65 S	65	28	-	4	

(1) Max. flow for clean non-viscous liquids, height = 1 m.

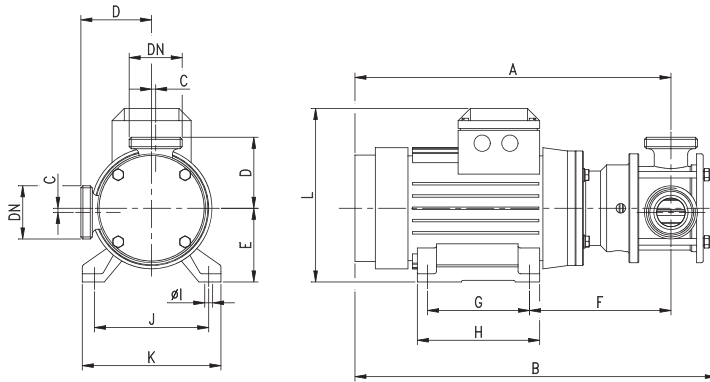

TYPE	Motor 1500		DN	A	B	C	D	E	F	G	H	ØI	J	K	L
	Size	kW													
RF-02/20 S	80	0,75	25	314	350	2	70	80	139	100	125	10	125	155	190
RF-05/25 S				323	370				148						
RF-10/40 S	90	1,5	40	388	445	5	87	90	174	125	150		140	170	212
RF-20/50 S	100	3	50	440	510	6,5	103	100	205	140	175	12	160	200	236

TYPE	DN	Ød	A	B	C	D	E	F	G	H	ØI	J	K	L
RF-02/20 S	25	19	172	206	2	70	80	74	30	60	9	70	90	40
RF-05/25 S			181	225				83						
RF-10/40 S	40	24	210	265	5	87	90	88	45	70	10	80	105	50
RF-20/50 S	50	28	272	335	6,5	103	100	109	75	105	11	90	120	60
RF-30/65 S	65		280	350	10	112		117						

