

GLOBALGEAR® PUMPS



■ Versatile Pumps
that are Easy to
Maintain.



TUTHILL
Pump Group

Engineered Solutions

GlobalGear® builds on a time-tested design and more than 75 years of gear pump engineering experience. Capable of tackling the toughest high-viscosity applications, the GlobalGear® Process Pump handles everything from bulk transfer, chocolate and asphalt, to high-temperature fluids and chemical processing.

With GlobalGear's® modular construction, maintenance and service have never been easier. Developed with tough parts and universal features, our patented design reduces stocking inventories by providing alternatives with minimal switching costs. The result? An unbeatable pump that delivers unparalleled performance.

GLOBALGEAR® PUMPS



TUTHILL GLOBALGEAR® PROCESS PUMPS – *The Pump designed for you!*

You told us what you needed in a high-performance process pump – we heard you loud and clear. Our answer is the GlobalGear® Process Pump Series. From the cost-effective GG015 to the workhorse GG250, the entire GlobalGear® Series employs tougher, more reliable parts that have never been easier to service and maintain. Numerous engineering and mechanical patents make our innovative, modular design uniquely equipped to handle the growth and change of your business's needs. And GlobalGear's ability to reduce expensive inventories and provide alternatives with minimal switching costs saves you valuable time and money. Tuthill has created the Pump designed for You – the GlobalGear® Process Pump.

GlobalGear® Pumps are **TOUGHER AND MORE RELIABLE.**

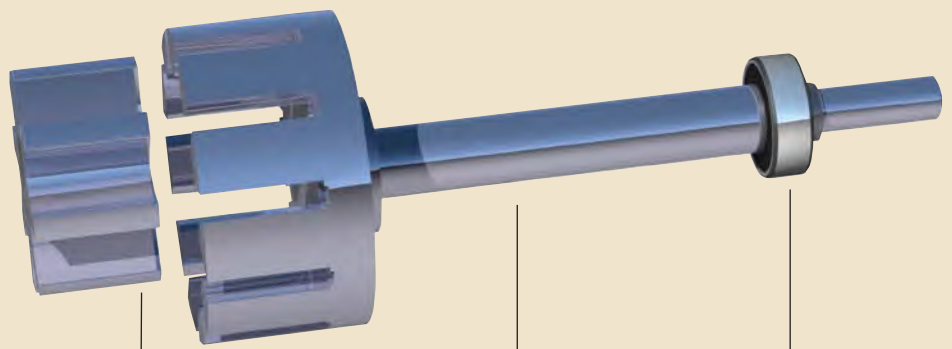

TOUGH GEARS

The rotor and idler gears are made of tough materials, which can handle the stresses of high-viscosity and high-pressure operation.

PATENTED LUBRICATION FEATURE

Revolutionary lubrication method extends overall life by reducing friction

STRONG SHAFT DESIGN

Models employ high-strength shaft materials. This, along with oversized shaft diameters, ensures a strong, reliable shaft.

ROBUST BEARING

Oversized ball bearings are used to ensure years of trouble-free operation.

GlobalGear® Pumps are designed to **REDUCE YOUR INVENTORY.**

STANDARD SHAFT SIZES

Standard shaft sizes let you use seals you probably already have for other rotating equipment. And this applies no matter where you are, because GlobalGear® pumps are available with your choice of nominal inch or metric shaft sizes.



SPARE DRIVE MODULES

The back pull-out design allows you to stock a spare drive module instead of a complete pump.



GlobalGear® Pumps have never been **EASIER TO MAINTAIN.**

BACK PULL-OUT

The back pull-out design greatly reduces down-time for service—the pump can be repaired without disturbing piping or shaft alignment.

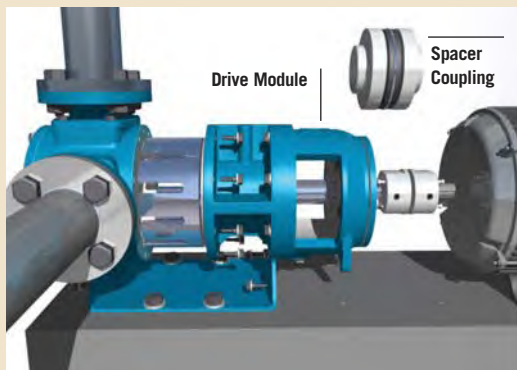

Downtime

- A. Typical time to replace complete pump
- B. Typical time to replace GlobalGear® drive module



INLINE SEAL ACCESS

Inline seal access design reduces seal maintenance time—the seal can be removed without disturbing the piping or shaft alignment.

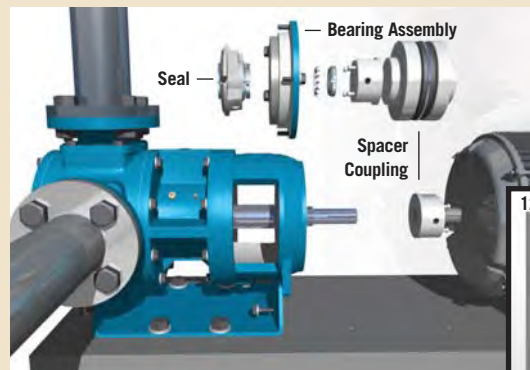

Downtime

- A. Typical time to replace seal in pump without inline feature
- B. Typical time to replace seal in GlobalGear® pump



GlobalGear® Pumps provide alternatives with **MINIMAL SWITCHING COSTS.**

NO PIPING CHANGES

GlobalGear® mounting dimensions match those of most other gear pumps.

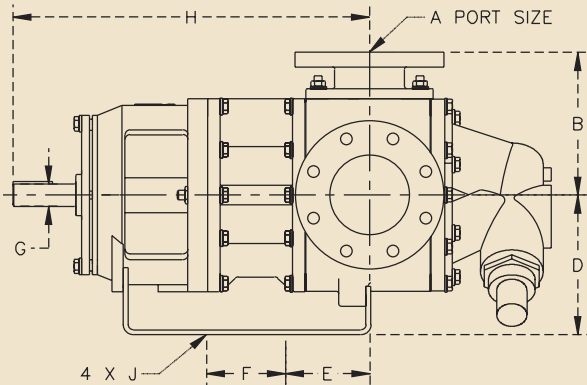

NO DRIVE CHANGES

At any given speed, the GlobalGear®'s flow rates match those of most other gear pumps.



Flow Rate

A. GG130
at 780 RPM

B. Other gear pump
at 780 RPM

SPECIFICATIONS

CAST IRON AND CARBON STEEL

Model	Max RPM	Nominal Flow Rate			
		USGPM		M ³ /HR	
GG015	1800	15 @ 1750 RPM		2.8 @ 1450 RPM	
GG030	1800	30 @ 1750 RPM		5.7 @ 1450 RPM	
GG050	1500	38 @ 1150 RPM		6.9 @ 920 RPM	
GG070	1500	50 @ 1150 RPM		9.1 @ 920 RPM	
GG080	1500	60 @ 1150 RPM		10.9 @ 920 RPM	
GG090	1500	75 @ 1150 RPM		13.7 @ 920 RPM	
GG120	1200	75 @ 780 RPM		20.0 @ 920 RPM	
GG130	1000	100 @ 780 RPM		27.0 @ 920 RPM	
GG200	1000	135 @ 640 RPM		31.0 @ 640 RPM	
GG210	800	140 @ 520 RPM		32.0 @ 520 RPM	
GG250	640	200 @ 640 RPM		45.4 @ 640 RPM	
GG500*	520	500 @ 520 RPM		113.5 @ 520 RPM	
GG550*	500	550 @ 500 RPM		124.5 @ 500 RPM	

Pressures to 200 psi (13.8 bar)

Temperatures to 600°F (316°C)

Viscosities to 1,000,000 ssu (220,000 cst)

*Pressures to 150 PSI (10 bar)

*Temperatures to 400°F (204°C)

STAINLESS STEEL

Model	Max RPM	Nominal Flow Rate			
		USGPM		M ³ /HR	
GG015	1200	10 @ 1150 RPM		1.8 @ 920 RPM	
GG030	1200	20 @ 1150 RPM		3.7 @ 920 RPM	
GG050	1000	25 @ 780 RPM		5.7 @ 780 RPM	
GG070	1000	35 @ 780 RPM		7.9 @ 780 RPM	
GG080	1000	40 @ 780 RPM		9.1 @ 780 RPM	
GG090	1000	50 @ 780 RPM		11.4 @ 780 RPM	
GG120	800	50 @ 520 RPM		11.4 @ 520 RPM	
GG130	640	65 @ 520 RPM		14.8 @ 520 RPM	
GG200	640	90 @ 420 RPM		20.5 @ 420 RPM	
GG210	520	110 @ 420 RPM		25.0 @ 420 RPM	
GG250*	520	160 @ 520 RPM		36.3 @ 520 RPM	

Pressures to 150 psi (10.3 bar)

Temperatures to 500°F (260°C)

Viscosities to 1,000,000 ssu (220,000 cst)

*Pressures to 100 psi (6.9 bar)

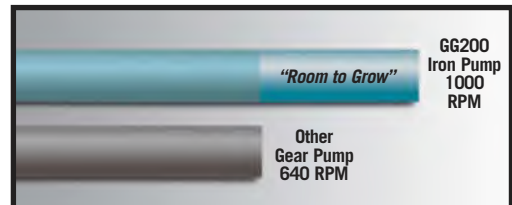

MAXIMUM SPEEDS

Faster top speeds allow increased flow rate if needs change.



GlobalGear® Pump's **MODULAR DESIGN** will evolve with your business's changing needs.

MODULAR PORTS

Several port styles are available to match your piping needs:

- 90° (shown) or 180° port options
- NPT tapped
- BSPT tapped
- ANSI 125#/150# flanged
- ANSI 250#/300# flanged
- ISO PN16 flanged
- ISO PN40 flanged

Each pump size has numerous port size choices to minimize piping losses.

For example, GG200 size offers these choices:

- 2" or 50mm
- 2 1/2" or 65mm
- 3" or 80mm
- 4" or 100mm



Shown: GG200 with 2" NPT side port and ANSI 125# top port

MODULAR SEAL CHAMBER

Modular seal chamber provides a choice of packing, mechanical seal or cartridge seal—without changing major pump components. Our patented bracket and seal enhance the already flexible and versatile design.

