

VERDERFLEX[®]
DURA

Verderflex DURA
Peristaltic Hose Pump

VEDDER
VERDER 

Solutions in Pumping Technology



Verderflex Dura industrial hose pump

With the introduction of the new Verderflex® DURA range of pumps the Verder Group has moved its range of peristaltic hose pumps to a new level.

The DURA series form a new generation of smaller hose pumps; the DURA10, DURA15 and DURA25, based on an innovative long coupled design with close coupled advantages. The features of this pump surpass all other hose pumps giving Verder the world's most reliable, robust pump with exceptional dosing features.

Benefits of the Verderflex® Dura:

- Longer hose life†
- Quick & easy maintenance
- Long coupled design with close coupled advantages
- 70% smaller footprint †
- Up to 25% reduction in operational noise

Dura's Unique Design

Verderflex's contribution to your productivity with its new generation pumps, simply serves to highlight our commitment to solutions in pumping technology.

- The rotor is mounted on a drive shaft, which is located on a dual bearing hub. The bearing construction is 'sealed for life' and centrally absorbs the forces released in the pump. This results in quieter operation and a more durable pump and drive. The unique drive shaft has been designed to dramatically reduce the loading on the gearbox and motor.
- The DURA series has an ultra-compact construction, which dramatically reduces required floor space by up to 70% in contrast to other comparable pumps.
- The DURA range of pumps are easy to install, virtually maintenance free and special versions comply with ATEX standards.
- A significant reduction in operating temperature leads to improved hose life when compared to an equivalent pump type.
- Other features specific to this pump include the improved frame design and a one-size-fits-all slotted flange solution, incorporating ANSI; JIS & DIN to connect the Verderflex® DURA pump to the pumping station. The entire range incorporates a rapid change taper-lock flange, which is suitable for pressures of up to 12 Bar / 175 PSI*.

With high corrosion and abrasion resistance and an extended hose life, there can be no question that this pump is a real breakthrough in pumping technology.

Without any seals or valves, a Verderflex® peristaltic pump is ideal for handling:

- Abrasive fluids
- Corrosive fluids
- Viscous fluids
- Shear sensitive fluids
- High density fluids
- High Solid content fluids





Advantages of the Verderflex® Dura

- Low maintenance - the hose is the only wearing part ensuring minimal downtime.
- Reduced operating temperature leads to improved hose life.†
- A one piece taper-lock flange connection offers a quick and reliable hose change.
- The unique design has reduced the required power consumption, the size of the motor and gearbox which now takes up 70% less space.†
- A fast and simple gearbox change ensures maximum 'Up-Time' reducing maintenance costs.
- The quieter action and GMU (Gear Motor Unit) reduces installed noise providing Health and Safety benefits.
- Other benefits which offer increased reliability and in turn reduce overall maintenance costs include a torque-only coupled drive with no overhung load and 'sealed for life' drive shaft bearings that are mounted within the housing.
- Potential blockages at suction port - pump can run dry and be reversed to unblock the suction line

Dura Technical Overview:

	Max Speed	Max Power		Flow Rates		Max Pressure	
	(RPM)	(kW)	(HP)	Min (l/h)	Max(l/h)	(bar)	(PSI)
DURA10	100	0.35	0.50	13.9	139.2	12*	175*
DURA15	100	0.55	0.75	45.6	456.0	12*	175*
DURA25	100	1.7	2.5	170.5	1705.2	12*	175*

Materials of Construction

Description	Material	Description	Material
Pump housing	Cast Steel (RAL 6018 - Green)	Torque arm	EN10025 Structural Steel (RAL 7021)
Front cover	Polycarbonate	Bearing	Stainless Steel
Rotor	Cast Aluminium - Option: Cast Iron	Shaft Seal	NBR option Viton,PTFE
Drive shaft	EN24T Steel	Lubricant	Verderlube - Glycerine based lubricant
Flange	316 Stainless Steel		Verdersil - Silicon based lubricant
Flange coating option	Halar® Anti Corrosion Coating	Hose	NR, NBR, NBRF, EPDM & CSM
Base frame	Powder Coated Mild Steel		

Weights

	Dura 10	Dura 15	Dura 25
Complete pump	19 Kg	30 Kg	49 Kg
Inverter (Optional)	3 Kg	3 Kg	3 Kg

Application areas

The unique design of Verderflex® peristaltic pumps make them ideally suited to a wide range of application areas, including:

- Abrasive products such as lime. Abrasion is not a limiting factor for the pump as the hose is the only wearing part to come into contact with the product circulating through the pump
- High dosing accuracy & repeatability - there is no product slip in the hose, this gives a 100% volumetric efficiency with a linear speed flow characteristic
- Corrosive liquids such as Ferric Chloride, Copper Sulphate and similar activators, process chemicals, acids and including aggressive alkalis - only the hose and the one piece flange are in contact with the pumped fluid
- Shear sensitive products such as coagulants, flocculants and bacterial remediation treatments - the gentle low shear peristaltic action does not damage your product and maintains particle size
- Crystallising and settling media - there are no valves or glands where crystals or product can build up and block the pump
- Highly viscous products - exceptionally high suction levels allow transportation of high viscosity liquids
- Self-priming applications - pumps can run dry and pump products that produce gas including Sodium Hypochlorite and Yeast
- Products with high concentration of solids - up to 80% in organic solid content can be handled, e.g. mining slurries
- Products with a high specific gravity, e.g. slurries with SGs over 2.0

Performance Curves - Dura 10

Several different generic types of gearbox may be fitted to the Dura pump. Due to the varying mechanical efficiencies of these types, motors may be specified that have much higher absorbed powers than indicated by the pumpehead absorbed power or torque and as shown on the performance graphs

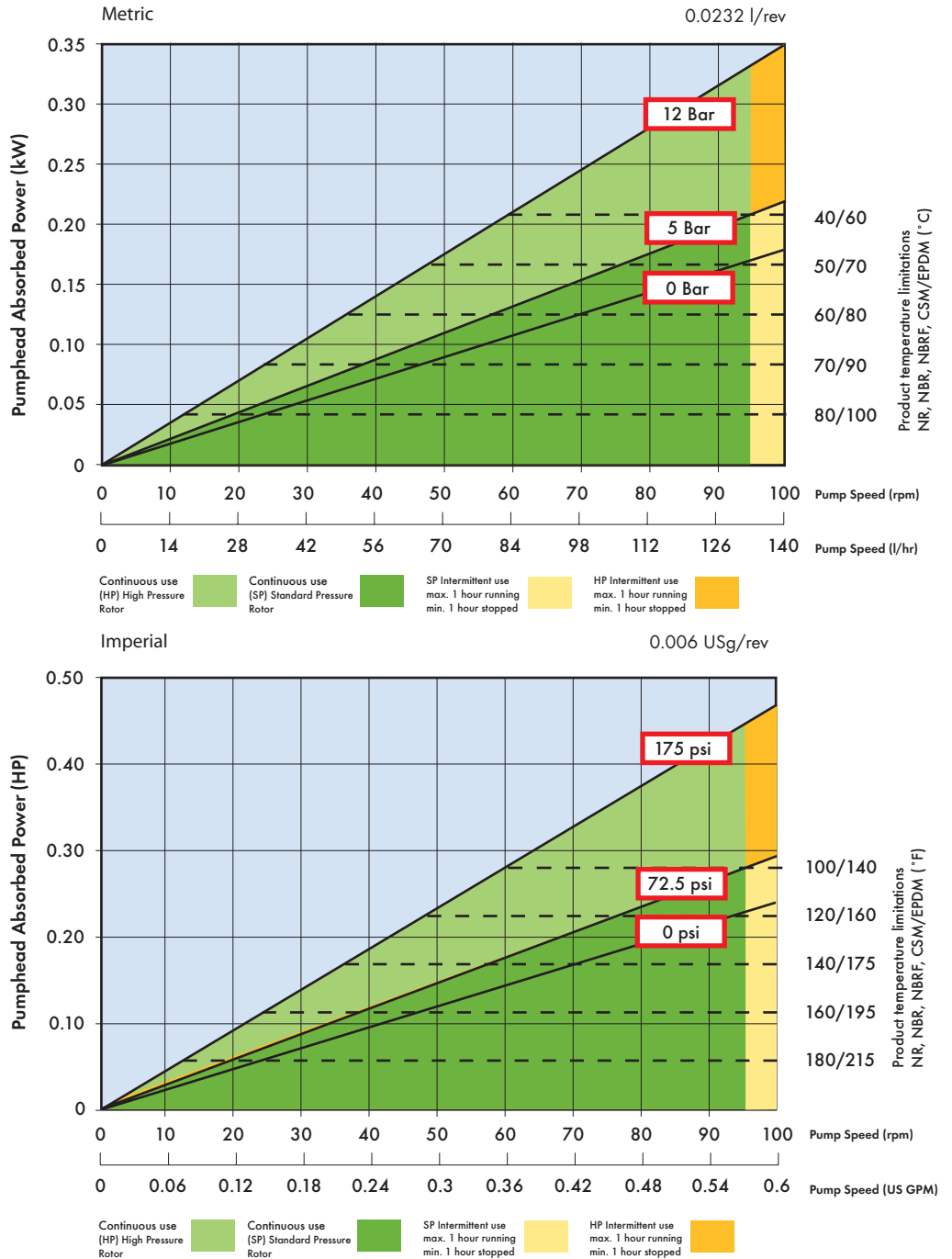

Note: Drive selections should only be made from the drive selection tables given in the Dura datasheets

General Arrangement Layout

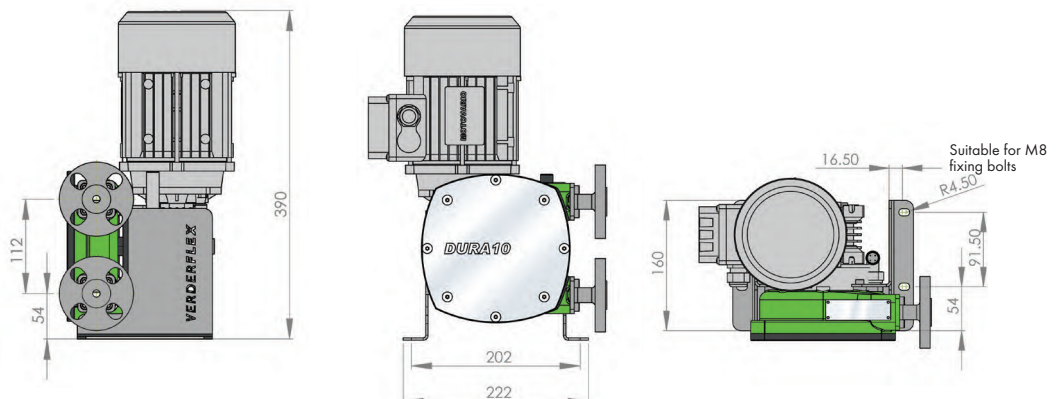

The drawings are for guidance only. For mounting drawings please contact a authorised Verderflex® distributor.

Note: All Verderflex® Dura pump units above 8 bar are special order.

Performance Curves - Dura 15

Several different generic types of gearbox may be fitted to the Dura pump. Due to the varying mechanical efficiencies of these types, motors may be specified that have much higher absorbed powers than indicated by the pumphead absorbed power or torque and as shown on the performance graphs

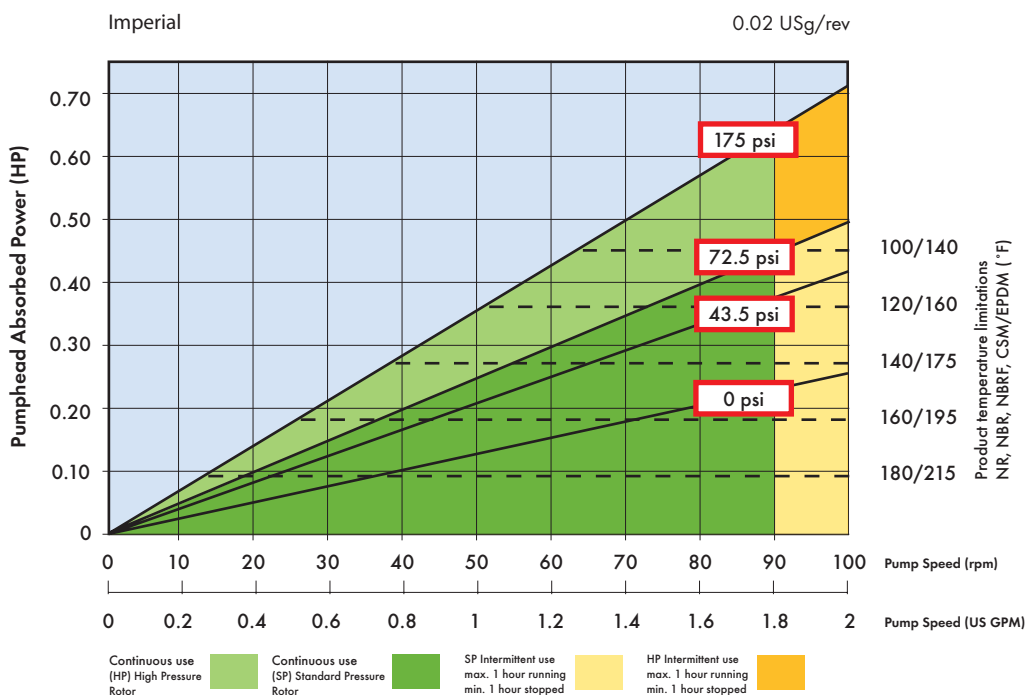
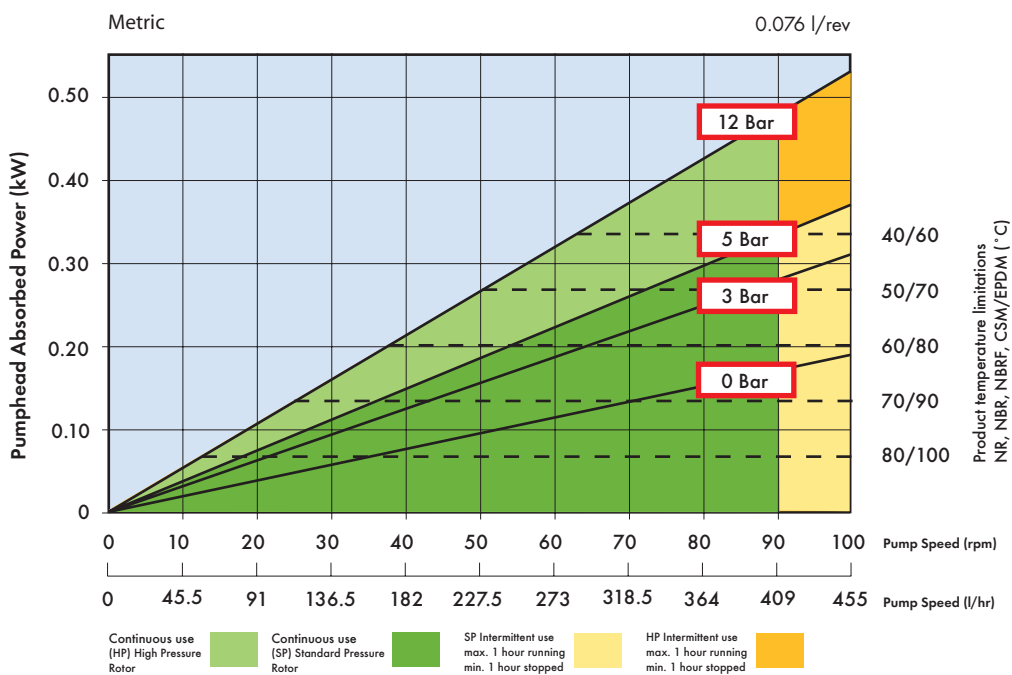

Note: Drive selections should only be made from the drive selection tables given in the Dura datasheets

General Arrangement Layout

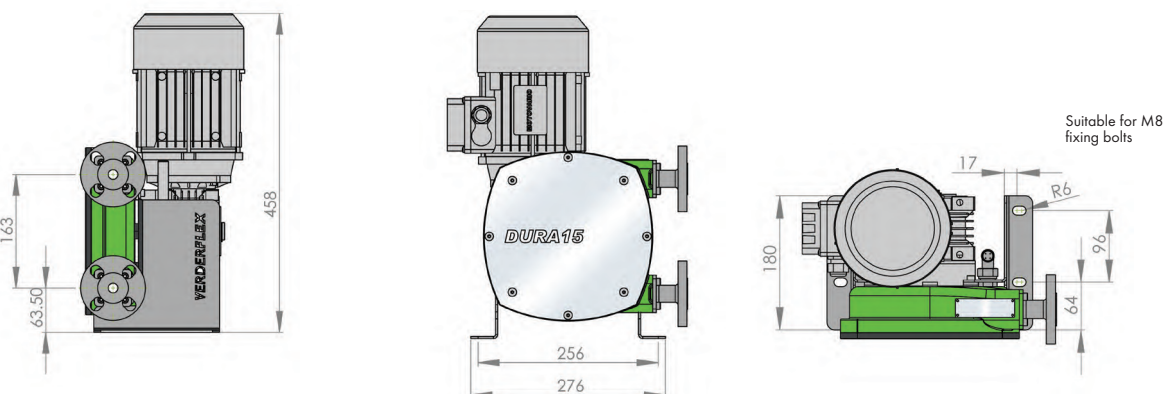

The drawings are for guidance only. For mounting drawings please contact a authorised Verderflex distributor.

Note: All Verderflex® Dura pump units above 8 bar are special order.

Market segments

- Mining industry - dosing process reagents, polymers and slurry transfer
- Water treatment - Dosing Lime, Hypochlorite, Silicate, Polymer, Ferric Chloride; transferring sludge and filter press feeds
- Chemical industry - corrosive acids, alkalis, bases and hydrocarbons
- Paints and coatings - Dosing of inks
- Textile industry - Dosing of dyes
- Ceramic industry - Pumping highly abrasive product
- Paper and pulp - Pulp, dyes
- Cosmetics
- Recycling & Waste Remediation
- Food and beverage - Breweries, wineries, dairies, sugar refining, bakeries, abattoirs
- Agriculture - Feed additives, animal vaccines and waste transfer

Performance Curves - Dura 25

Several different generic types of gearbox may be fitted to the Dura pump. Due to the varying mechanical efficiencies of these types, motors may be specified that have much higher absorbed powers than indicated by the pumphead absorbed power or torque and as shown on the performance graphs

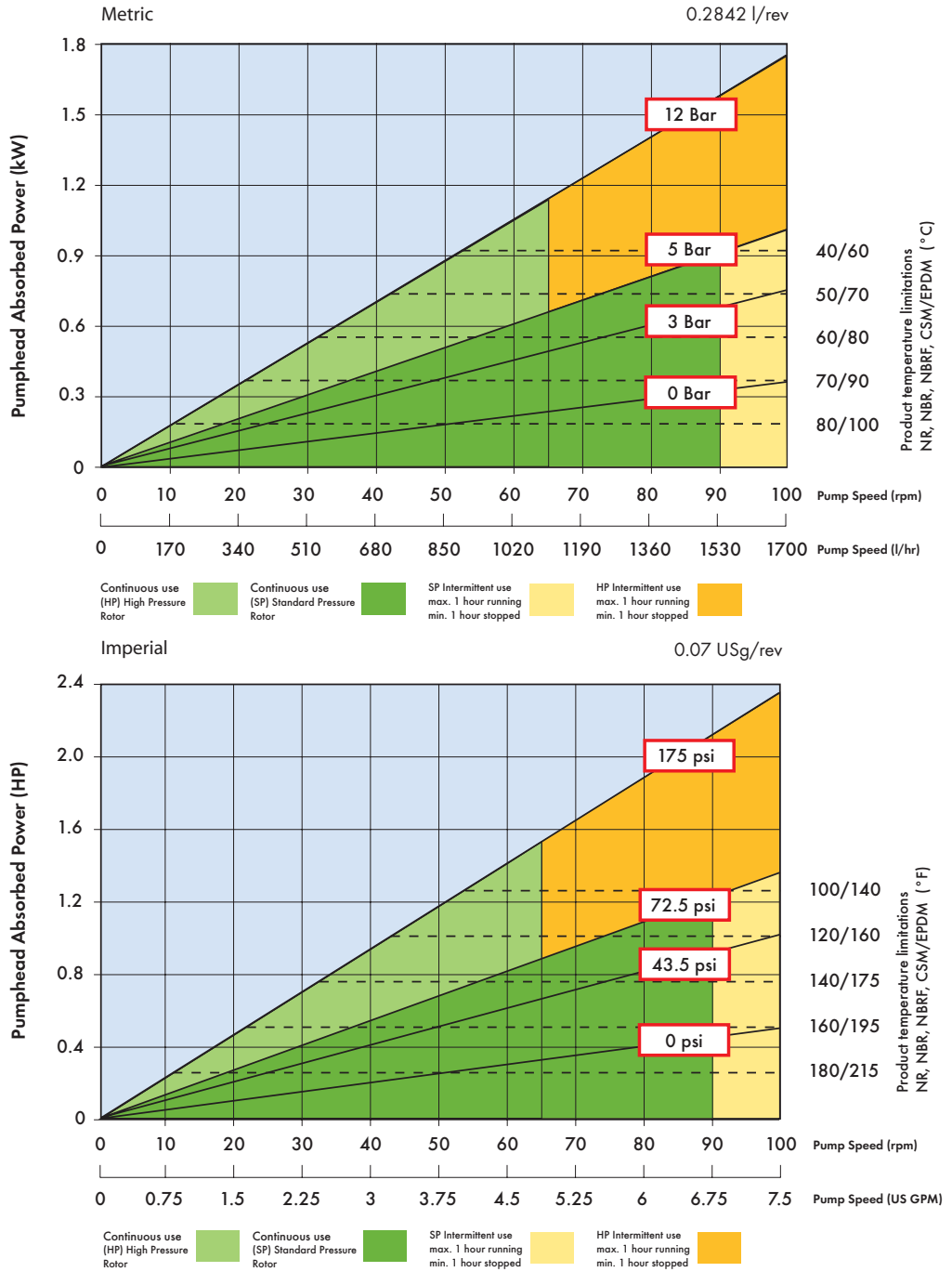

Note: Drive selections should only be made from the drive selection tables given in the Dura datasheets

General Arrangement Layout

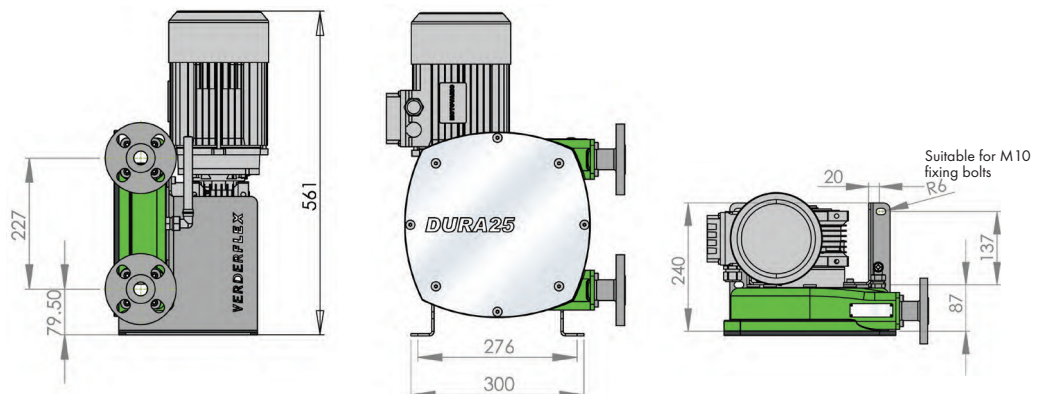

The drawings are for guidance only. For mounting drawings please contact a authorised Verderflex® distributor.
Note: All Verderflex® Dura pump units above 8 bar are special order.

The Verderflex® hose

The Verderflex® hose has a custom engineered construction which increases the strength in the reinforced layers between the rubber. This maximises the fatigue strength thereby extending the hose life. This superior hose design when combined with the advanced rotor profile of the Verderflex® Dura further enhances the durability of the hose which in turn maximises the 'Up-Time' of the pump.

Technical Summary

- 3 standard hose sizes
- All are designed to maximise hose life by optimising the hoses' fatigue strength
- Hoses are available in Natural Rubber (NR), Nitrile Buna Rubber (NBR), Food Grade NBRF, EPDM and Hypalon® (CSM)
- Hoses have colour coded identification tapes bonded into the outer surface during manufacture to clearly identify material type

Internal diameter of the hose and rotor speed determine the flow rate of the pump. Hose wall thickness compared to its diameter and the number of reinforcement layers are responsible for the restitution of the hose after compression which creates a virtual vacuum in the hose. The construction of the textile reinforcement allows a discharge pressure of the pump of up to 12Bar/175 PSI for all pump types.

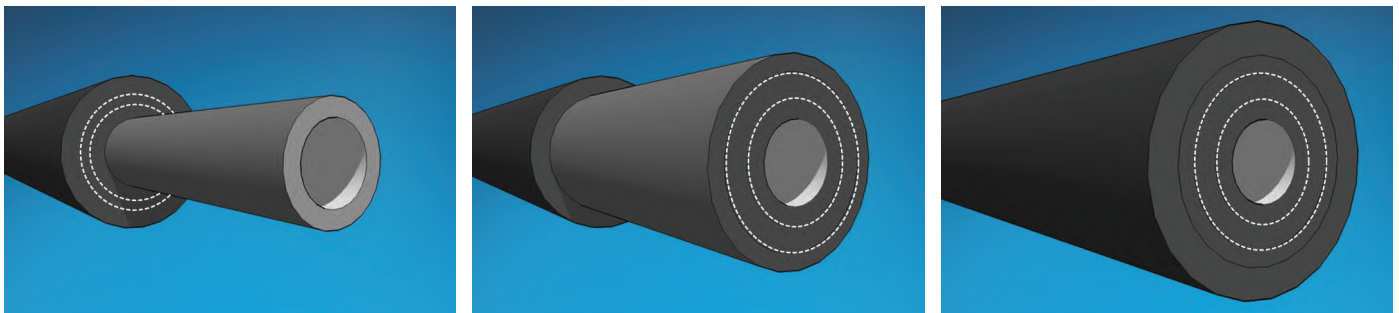

Surface properties of the hose

Some industrial hose pumps in today's market have machined exteriors, a process generally employed to achieve an equal wall thickness. In comparison, the unique Verderflex® production process is so precise that the exact wall thickness and outer diameter tolerances are maintained at each and every point. For this reason Verderflex® hoses do not have to undergo this additional process of external machining. When Verderflex® hoses are tested alongside their competitors, results indicate that there is no additional friction loss due to the wound surface. The textured

surface actually creates micropockets of lubricant which promotes superior lubrication of the hose. All Verderflex® hoses have a coloured lettering on the exterior which indicates the type of hose. The Verderflex® lettering is white for a NR hose, yellow for a NBR, red for a EPDM hose type, yellow with a white stripe for the Food Grade NBRF and green for Hypalon® or CSM.

Hypalon® is a registered trademark of DuPont Dow Elastomers



“...specifically designed to reduce fatigue...”

“...resulting in an extremely long hose service life...”



Solutions in Pumping Technology

The Verder Difference

Pumps form an essential part of industrial processes for all our customers, which is why our starting point is your process and your specific needs. We provide a wide and complementary range of pumps and accessories on the basis of application and need. What's more, by offering technical and logistic services alongside an extensive knowledge of processes and applications positions us as a leading supplier.

The Verder Group offers a wide range of solutions for industrial applications:

- Liquids Technology – pumps, pumping systems and liquids/gas mixers
- Solids Handling Technology – equipment for processing and handling of solid materials
- Sample preparation – precise equipment for laboratory solids preparation and handling

Verder Liquids is active in many industries: chemicals, food, environment, water and general industry, we also offer excellent OEM solutions. Within these industries pump requirements vary enormously and applications and needs change frequently. In order to ensure we provide the best solutions we analyse and monitor industrial trends as well as maintaining close relationships with our customers.

Your advantages

The advantages of working with us are clear, we offer you:

- Single-source solutions: Verder's wide and complementary range of pumps allows you to source your entire pumping needs from one company, reducing your costs;
- Expertise: years of providing pumping solutions to industry have given us valuable expertise and knowledge which we are able to use to supply the most appropriate and reliable pumps;
- International affiliated company: our size gives you the confidence that you are dealing with a substantial international pump company and if your project involves overseas work then you can benefit from our international network of companies.
- In addition to the Verder Group operating companies, the Verderflex range is supported by a worldwide distribution network that provides local support and spares availability on all five continents.

The Verderflex® Series

Verderflex®

- Operating pressures to 16 Bar/230 PSI and flow rates to 90m³ /hour (390 US GPM)
- Simplified hose connection for easy maintenance
- Specially designed hose construction for longer hose service life
- Supplied in close coupled or long coupled (bare shaft) styles
- DIN, ANSI and JIS flanges or hygienic compliant connections
- Certified to EHEDG standards for use in the food and drinks industry
- Can be supplied with pulsation dampers
- Supplied with a 2 year warranty covering any defects in workmanship and material under normal use

Verderflex® Smart Tube Pump

- Flows from 0.25ml/min (0.004 US GPH) to 27 l/min (428 US GPH)
- Maximum discharge pressures up to 4 bar (60 PSI)
- Four sizes of IP 55 digitally controlled programmable multi channel tube pumps
- Industrial style Smart F-series design using standard gear motor unit & optional inverter for process plants
- Wide range of tube materials including Verderprene and Silicone
- Easy-fit self adjusting tube saddle.
- External interfaces : 0-10V, 4-20 mA, RS 232

